

## ESECUZIONI STANDARD

Acciaio INOX AISI 304:

- **GN 136-NI-A:** senza fori, per saldatura.
- **GN 136-NI-B:** fori per viti a testa cilindrica.
- **GN 136-NI-C:** fori con sede per viti a testa svasata piana.
- **GN 136-NISW-B:** fori per viti a testa cilindrica, rivestimento resina epossidica, colore nero.

Acciaio zincato (perno in acciaio INOX AISI 304):

- **GN 136-ST-B:** fori per viti a testa cilindrica.
- **GN 136-ST-C:** fori con sede per viti a testa svasata piana.

## ANGOLO DI ROTAZIONE (VALORE APPROSSIMATIVO)

Max 280° (-100° e +180° essendo lo 0° la condizione di complanarità delle superfici interconnesse).

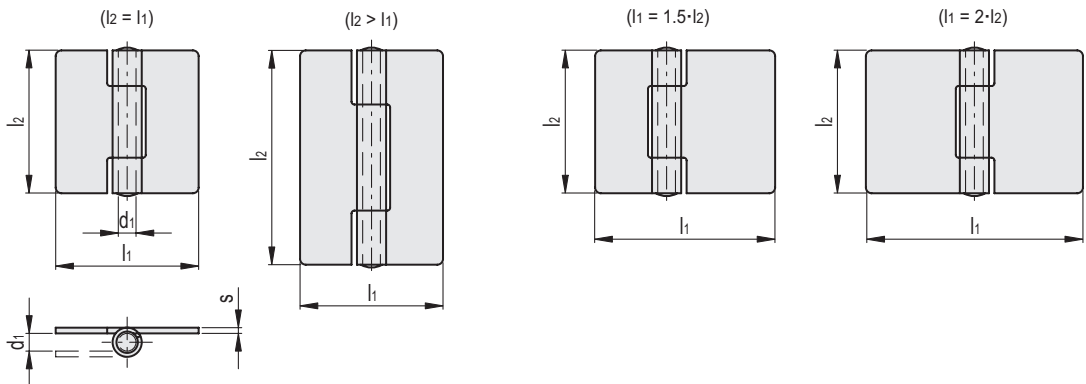
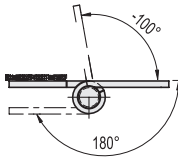

## GN 136-NI-A

INOX STAINLESS STEEL

Codice	Descrizione	l1	l2	d1	s	△△
GN.44598	GN 136-NI-30-30-A	30	30	3	1.5	15
GN.44607	GN 136-NI-30-45-A	30	45	3	1.5	22
GN.44601	GN 136-NI-40-40-A	40	40	4	2	36
GN.44604	GN 136-NI-40-60-A	40	60	4	2	52
GN.44646	GN 136-NI-45-30-A	45	30	3	1.5	20
GN.44611	GN 136-NI-50-50-A	50	50	6	2	63
GN.44614	GN 136-NI-50-75-A	50	75	6	2	93
GN.44649	GN 136-NI-60-30-A	60	30	3	1.5	25
GN.44652	GN 136-NI-60-40-A	60	40	4	2	47
GN.44621	GN 136-NI-60-60-A	60	60	6	2	85
GN.44624	GN 136-NI-60-90-A	60	90	6	2	122
GN.44655	GN 136-NI-75-50-A	75	50	6	2	81
GN.44658	GN 136-NI-80-40-A	80	40	4	2	59
GN.44661	GN 136-NI-90-60-A	90	60	6	2	111
GN.44664	GN 136-NI-100-50-A	100	50	6	2	98
GN.44667	GN 136-NI-120-60-A	120	60	6	2	139

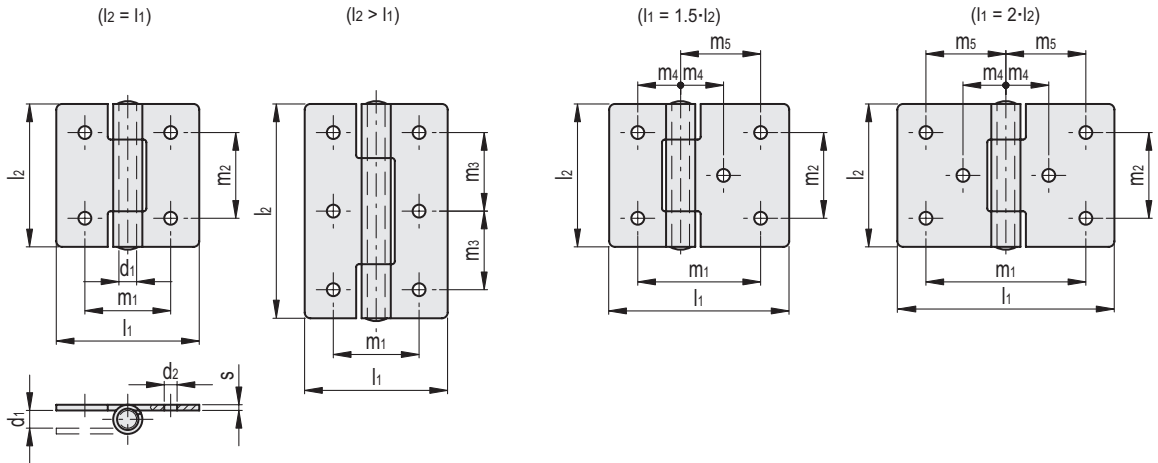

## GN 136-ST-B

Codice	Descrizione	l1	l2	d1	d2	m1	m2	m3	m4	m5	s	⚖
GN.44627	GN 136-ST-30-30-B	30	30	3	3.2	18	18	-	-	-	1.5	14
GN.44629	GN 136-ST-30-45-B	30	45	3	3.2	18	-	16.5	-	-	1.5	21
GN.44631	GN 136-ST-40-40-B	40	40	4	4.2	25	25	-	-	-	2	32
GN.44634	GN 136-ST-40-60-B	40	60	4	4.2	25	-	22.5	-	-	2	51
GN.44671	GN 136-ST-45-30-B	45	30	3	3.2	33	18	-	9	24	1.5	19
GN.44633	GN 136-ST-50-50-B	50	50	6	5.2	30	30	-	-	-	2	62
GN.44636	GN 136-ST-50-75-B	50	75	6	5.2	30	-	27.5	-	-	2	84
GN.44673	GN 136-ST-60-30-B	60	30	3	3.2	48	18	-	9	24	1.5	24
GN.44675	GN 136-ST-60-40-B	60	40	4	4.2	45	25	-	12.5	32.5	2	45
GN.44642	GN 136-ST-60-60-B	60	60	6	5.2	36	36	-	-	-	2	90
GN.44644	GN 136-ST-60-90-B	60	90	6	5.2	36	-	33	-	-	2	125
GN.44677	GN 136-ST-75-50-B	75	50	6	5.2	55	30	-	15	40	2	79
GN.44679	GN 136-ST-80-40-B	80	40	4	4.2	65	25	-	12.5	32.5	2	58
GN.44681	GN 136-ST-90-60-B	90	60	6	5.2	66	36	-	18	48	2	108
GN.44683	GN 136-ST-100-50-B	100	50	6	5.2	80	30	-	15	40	2	98
GN.44685	GN 136-ST-120-60-B	120	60	6	5.2	96	36	-	18	48	2	136

## GN 136-NI-B

INOX STAINLESS STEEL

Codice	Descrizione	l1	l2	d1	d2	m1	m2	m3	m4	m5	s	⚖
GN.44599	GN 136-NI-30-30-B	30	30	3	3.2	18	18	-	-	-	1.5	14
GN.44608	GN 136-NI-30-45-B	30	45	3	3.2	18	-	16.5	-	-	1.5	21
GN.44602	GN 136-NI-40-40-B	40	40	4	4.2	25	25	-	-	-	2	32
GN.44605	GN 136-NI-40-60-B	40	60	4	4.2	25	-	22.5	-	-	2	51
GN.44647	GN 136-NI-45-30-B	45	30	3	3.2	33	18	-	9	24	1.5	19
GN.44612	GN 136-NI-50-50-B	50	50	6	5.2	30	30	-	-	-	2	62
GN.44615	GN 136-NI-50-75-B	50	75	6	5.2	30	-	27.5	-	-	2	84
GN.44650	GN 136-NI-60-30-B	60	30	3	3.2	48	18	-	9	24	1.5	24
GN.44653	GN 136-NI-60-40-B	60	40	4	4.2	45	25	-	12.5	32.5	2	45
GN.44622	GN 136-NI-60-60-B	60	60	6	5.2	36	36	-	-	-	2	90
GN.44625	GN 136-NI-60-90-B	60	90	6	5.2	36	-	33	-	-	2	125
GN.44656	GN 136-NI-75-50-B	75	50	6	5.2	55	30	-	15	32.5	2	79
GN.44659	GN 136-NI-80-40-B	80	40	4	4.2	65	25	-	12.5	40	2	58
GN.44662	GN 136-NI-90-60-B	90	60	6	5.2	66	36	-	18	40	2	108
GN.44665	GN 136-NI-100-50-B	100	50	6	5.2	80	30	-	15	48	2	99
GN.44668	GN 136-NI-120-60-B	120	60	6	5.2	96	36	-	18	48	2	136

## GN 136-NISW-B

Codice	Descrizione	l1	l2	d1	d2	m1	m2	m3	m4	m5	s	⚖
GN.20783	GN 136-NISW-30-30-B	30	30	3	3.2	18	18	-	-	-	1.5	15
GN.20784	GN 136-NISW-30-45-B	30	45	3	3.2	18	-	16.5	-	-	1.5	22
GN.20785	GN 136-NISW-40-40-B	40	40	4	4.2	25	25	-	-	-	2	34
GN.20786	GN 136-NISW-40-60-B	40	60	4	4.2	25	-	22.5	-	-	2	52
GN.20787	GN 136-NISW-45-30-B	45	30	3	3.2	33	18	-	9	24	1.5	20
GN.20788	GN 136-NISW-50-50-B	50	50	6	5.2	30	30	-	-	-	2	61
GN.20789	GN 136-NISW-50-75-B	50	75	6	5.2	30	-	27.5	-	-	2	92
GN.20790	GN 136-NISW-60-30-B	60	30	3	3.2	48	18	-	9	24	1.5	25
GN.20791	GN 136-NISW-60-40-B	60	40	4	4.2	45	25	-	12.5	32.5	2	47
GN.20792	GN 136-NISW-60-60-B	60	60	6	5.2	36	36	-	-	-	2	83
GN.20793	GN 136-NISW-60-90-B	60	90	6	5.2	36	-	33	-	-	2	124
GN.20794	GN 136-NISW-75-50-B	75	50	6	5.2	55	30	-	15	40	2	81
GN.20795	GN 136-NISW-90-60-B	90	60	6	5.2	66	36	-	18	48	2	111
GN.20796	GN 136-NISW-100-50-B	100	50	6	5.2	80	30	-	15	40	2	100
GN.20797	GN 136-NISW-120-60-B	120	60	6	5.2	96	36	-	18	48	2	139

- 1
- 2
- 3
- 4
- 5
- 6
- 7
- 8
- 9
- 10
- 11
- 12
- 13
- 14
- 15
- 16
- 17
- 18
- 19

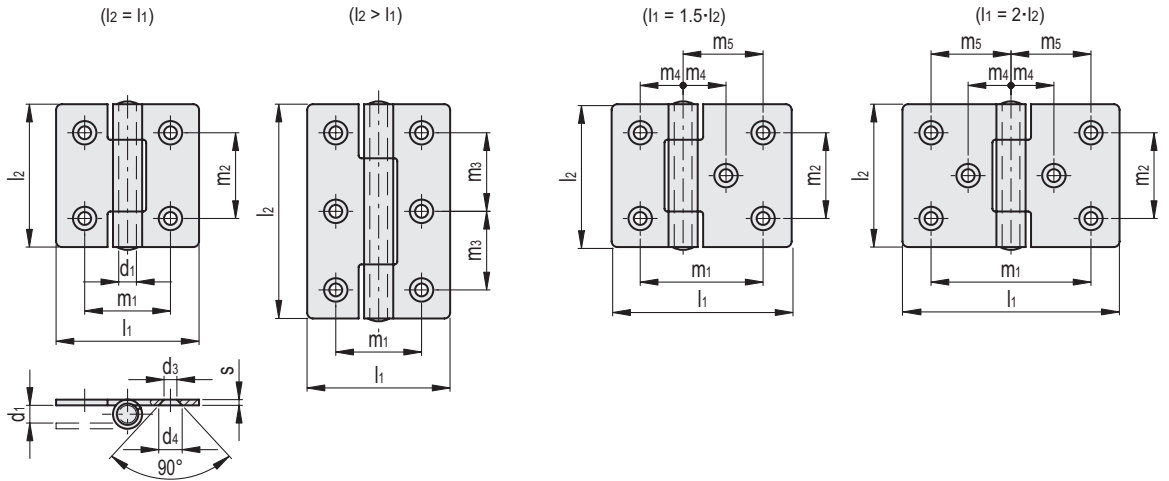

**GN 136-ST-C**

Codice	Descrizione	l1	l2	d1	d3	d4	m1	m2	m3	m4	m5	s	Δ
GN.44628	GN 136-ST-30-30-C	30	30	3	4	6.4	18	18	-	-	-	1.5	14
GN.44630	GN 136-ST-30-45-C	30	45	3	4	6.4	18	-	16.5	-	-	1.5	21
GN.44632	GN 136-ST-40-40-C	40	40	4	5	8.3	25	25	-	-	-	2	32
GN.44635	GN 136-ST-40-60-C	40	60	4	5	8.3	25	-	22.5	-	-	2	51
GN.44672	GN 136-ST-45-30-C	45	30	3	4	6.4	33	18	-	9	24	1.5	19
GN.44641	GN 136-ST-50-50-C	50	50	6	5	8.3	30	30	-	-	-	2	62
GN.44637	GN 136-ST-50-75-C	50	75	6	5	8.3	30	-	27.5	-	-	2	84
GN.44674	GN 136-ST-60-30-C	60	30	3	4	6.4	48	18	-	9	24	1.5	24
GN.44676	GN 136-ST-60-40-C	60	40	4	5	8.3	45	25	-	12.5	32.5	2	45
GN.44643	GN 136-ST-60-60-C	60	60	6	5	8.3	36	36	-	-	-	2	90
GN.44645	GN 136-ST-60-90-C	60	90	6	5	8.3	36	-	33	-	-	2	125
GN.44678	GN 136-ST-75-50-C	75	50	6	5	8.3	55	30	-	15	40	2	79
GN.44680	GN 136-ST-80-40-C	80	40	4	5	8.3	65	25	-	12.5	32.5	2	58
GN.44682	GN 136-ST-90-60-C	90	60	6	5	8.3	66	36	-	18	48	2	108
GN.44684	GN 136-ST-100-50-C	100	50	6	5	8.3	80	30	-	15	40	2	98
GN.44686	GN 136-ST-120-60-C	120	60	6	5	8.3	96	36	-	18	48	2	136

**GN 136-NI-C**

**INOX** STAINLESS STEEL

Codice	Descrizione	l1	l2	d1	d3	d4	m1	m2	m3	m4	m5	s	Δ
GN.44600	GN 136-NI-30-30-C	30	30	3	4	6.4	18	18	-	-	-	1.5	14
GN.44609	GN 136-NI-30-45-C	30	45	3	4	6.4	18	-	16.5	-	-	1.5	21
GN.44603	GN 136-NI-40-40-C	40	40	4	5	8.3	25	25	-	-	-	2	32
GN.44606	GN 136-NI-40-60-C	40	60	4	5	8.3	25	-	22.5	-	-	2	51
GN.44648	GN 136-NI-45-30-C	45	30	3	4	6.4	33	18	-	9	24	1.5	19
GN.44613	GN 136-NI-50-50-C	50	50	6	5	8.3	30	30	-	-	-	2	62
GN.44616	GN 136-NI-50-75-C	50	75	6	5	8.3	30	-	27.5	-	-	2	84
GN.44651	GN 136-NI-60-30-C	60	30	3	4	6.4	48	18	-	9	24	1.5	24
GN.44654	GN 136-NI-60-40-C	60	40	4	5	8.3	45	25	-	12.5	32.5	2	45
GN.44623	GN 136-NI-60-60-C	60	60	6	5	8.3	36	36	-	-	-	2	90
GN.44626	GN 136-NI-60-90-C	60	90	6	5	8.3	36	-	33	-	-	2	125
GN.44657	GN 136-NI-75-50-C	75	50	6	5	8.3	55	30	-	15	40	2	79
GN.44660	GN 136-NI-80-40-C	80	40	4	5	8.3	65	25	-	12.5	32.5	2	58
GN.44663	GN 136-NI-90-60-C	90	60	6	5	8.3	66	36	-	18	48	2	108
GN.44666	GN 136-NI-100-50-C	100	50	6	5	8.3	80	30	-	15	40	2	110
GN.44669	GN 136-NI-120-60-C	120	60	6	5	8.3	96	36	-	18	48	2	136

Cerniere e accessori